



Main Features:-

- ◆ 2pc Design Stainless Ball Valve
- ◆ Economy Wafer Pattern Ball Valve
- ◆ PN16 Flanged
- ◆ PTFE seats and Seals
- ◆ -10C to + 180C Temperature Rating CL 150

*Temperature and pressure determined by valve body, seat etc.



SERIES: 10120

MANUFACTURER: **AV@L**
INDUSTRIAL VALVES

Suitable Applications & Approvals:



SIZE	CODE	D	B	A	L	P	Q	S	T	W	KG
1 1/2"	1045-08	145	16	3	62	84.4	10	29.2	M6	198	4.0
2"	1045-09	155	18	3	72	91.8	10	28.8	M6	198	5.4
2 1/2"	1045-10	185	18	3	94	100.7	12	35.9	M8	248	9.2
3"	1045-11	200	20	3	118	131.3	12	36.8	M8	283	13.5
4"	1045-12	220	20	3	140	142.2	12	37.2	M8	333	19.3
6"	1045-14	285	22	3	182	181	17	51.4	M10	542	57.0

VALVE DIMENSIONS

DIMENSIONAL DRAWING OF VALVE

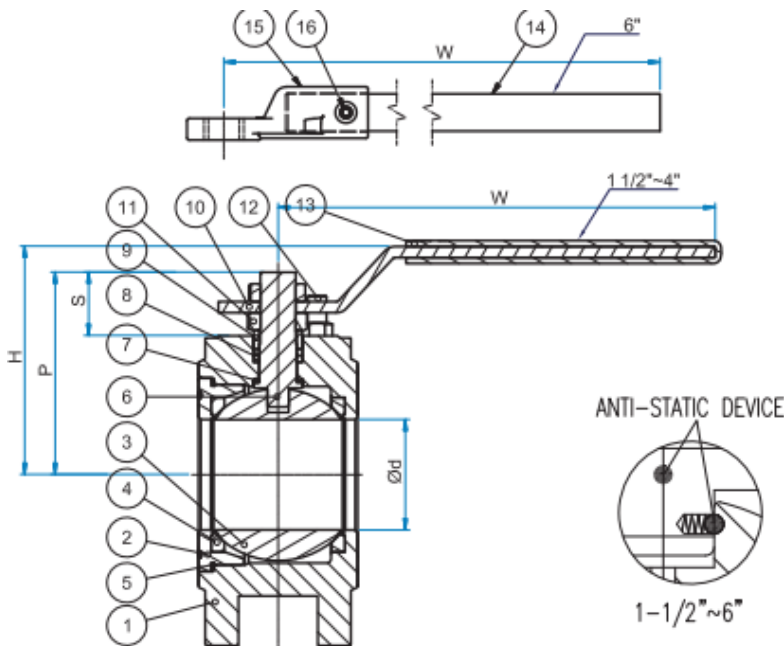

MATERIALS OF CONSTRUCTION

BODY	CF8M SS
BALL	CF8M
BODY SEAT	PTFE
STEM	316 SS
ORINGS	PTFE
PRESSURE	CL 150
TEMP	-20 to +180C

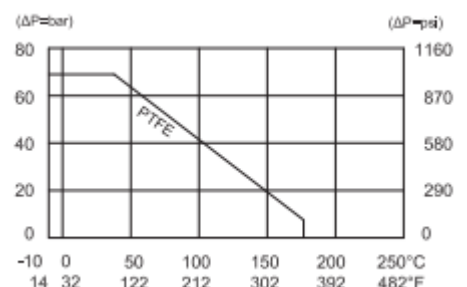

T +44 (0)1386 552369

W www.allvalves.co.uk

E sales@allvalves.co.uk

F +44 (0)1386 554227